

ELECTRIC POWERED VNA TRUCK

8RFBA 0.7 to 1.5 Ton Series

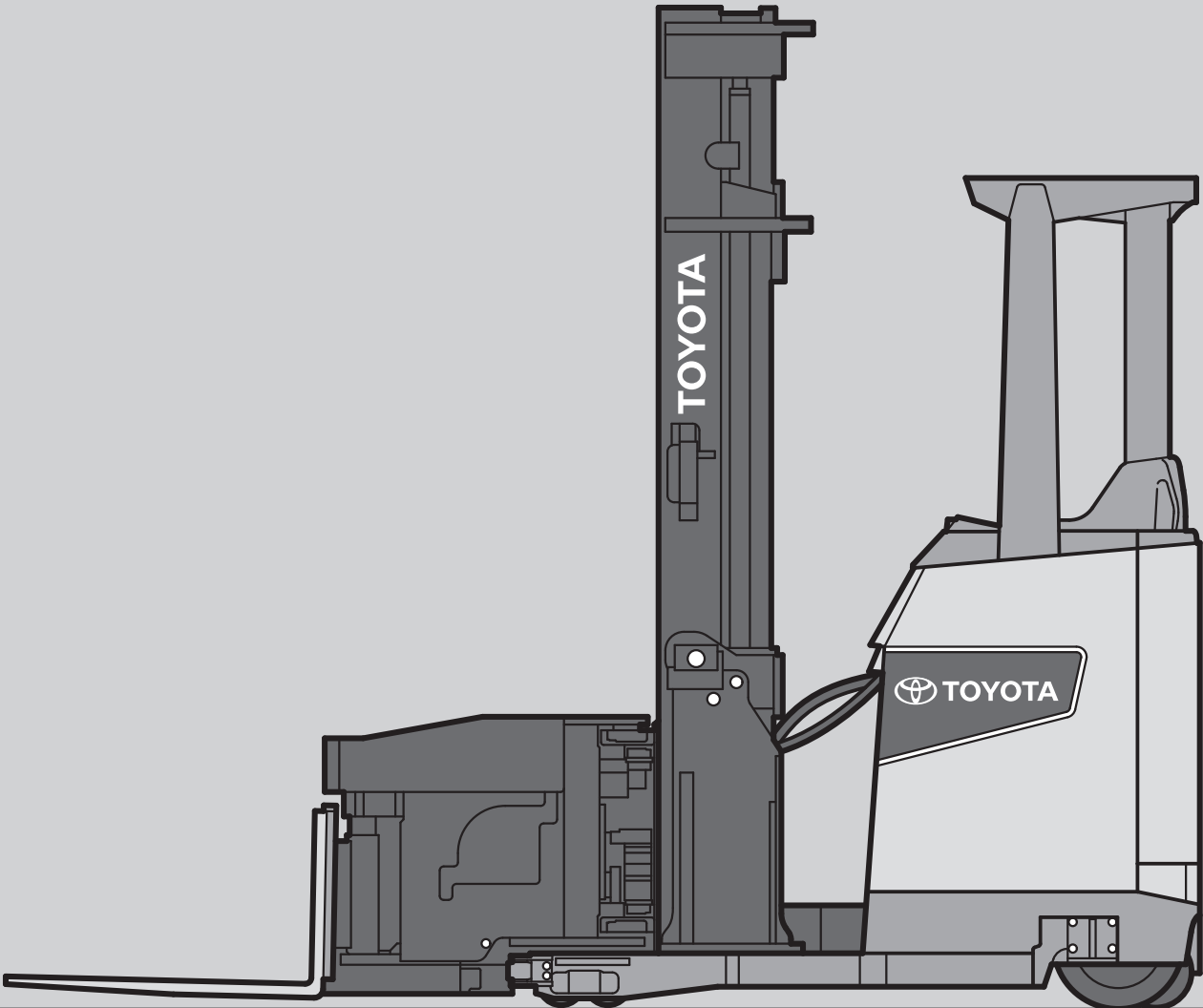

700 kg

MAIN VEHICLE SPECIFICATIONS

Manufacturer				TOYOTA	
Model				8RFBA7	
Load Capacity			kg	700	
Load Center			mm	550	
Operator Position				Stand On	
Tire Type		Front/Rear		Urethane/Rubber	
Wheels (x = driven)		Front/Rear		4/1x+2	
Maximum Fork Height (MFH)			mm	4000	
Free Lift			mm	75	
Fork Size		T x W x L	mm	30x100x850	
Fork Spread (Outside)		MAX./MIN.	mm	760/550	
Overall Length		Fork Facing Forward	mm	3160	
Length to Fork Face		Fork Facing Sideways	mm	2570	
Shift Stroke		Pallet Size 1100 x 1100/1200 x 1200	mm	1180/1280	
Overall Width		Pallet Size 1100 x 1100/1200 x 1200	mm	1450/1550	
Frame Width			mm	1090	
Height of Reach Legs			mm	140	
Mast Lowered Height			mm	2695	
Mast Extended Height			mm	4825	
Overhead Guard Height			mm	2250	
Turning Radius (Outside)			mm	1580	
Load Distance (Centerline of front axle to front face of forks)			mm	750	
Stacking Aisle Width		With pallets 1100x1100	mm	1480	
		With pallets 1200x1200	mm	1580	
Main Aisle Width		With pallets 1100x1100	mm	2930	
		With pallets 1200x1200	mm	3030	
Speed	Travel, Max. (FWD/RVS)	Full Load	km/h	9.5	
		No Load	km/h	10	
	Lifting	Full Load	mm/sec	350	
		No Load	mm/sec	430	
Lowering	Full Load	mm/sec	500		
	No Load	mm/sec	500		
Gradeability *	Full Load/ No Load	3-Minute Ratings	% (tanθ)	15/19	
		5-Minute Ratings	% (tanθ)	15/19	
		30-Minute Ratings	% (tanθ)	7/10	
Total Weight		With MIN. Battery	kg	3390	
Weight Distribution (With MIN. Battery)		Full Load	Front	kg	2850
			Rear	kg	1240
		No Load	Front	kg	1840
			Rear	kg	1550
Tire		Number	Front/Rear	4/1+2	
		Size	Front, Load		127x92
			Rear, Drive		334x145
			Rear, Caster		150x80
Wheelbase			mm	1350	
Tread		Front	mm	1240	
		Rear	mm	645	
Underclearance **		Center of Wheelbase	mm	50	
Brake		Service (Foot)		Disc	
		Parking		Disc	
Battery		Voltage/Capacity (5-hour rating)	MIN.	V/AH	48/280
		Weight (MIN. Capacity Type)		kg	480
Electric Motor		Drive	kW	4.9	
		Load Handling	kW	8	
		Power Steering	kW	0.26	
Control Type		Drive		AC inverter	
		Load Handling		AC inverter	
		Power Steering		DC chopper	
Rotating Speed			sec/180°	12	
Shifting Speed			mm/sec	230	

NOTE: * Computed values.

** The underclearance value is valid under the following conditions: 500 mm load center and the suspension spring in correct adjustment.

DIMENSIONAL DRAWINGS

Unit: mm

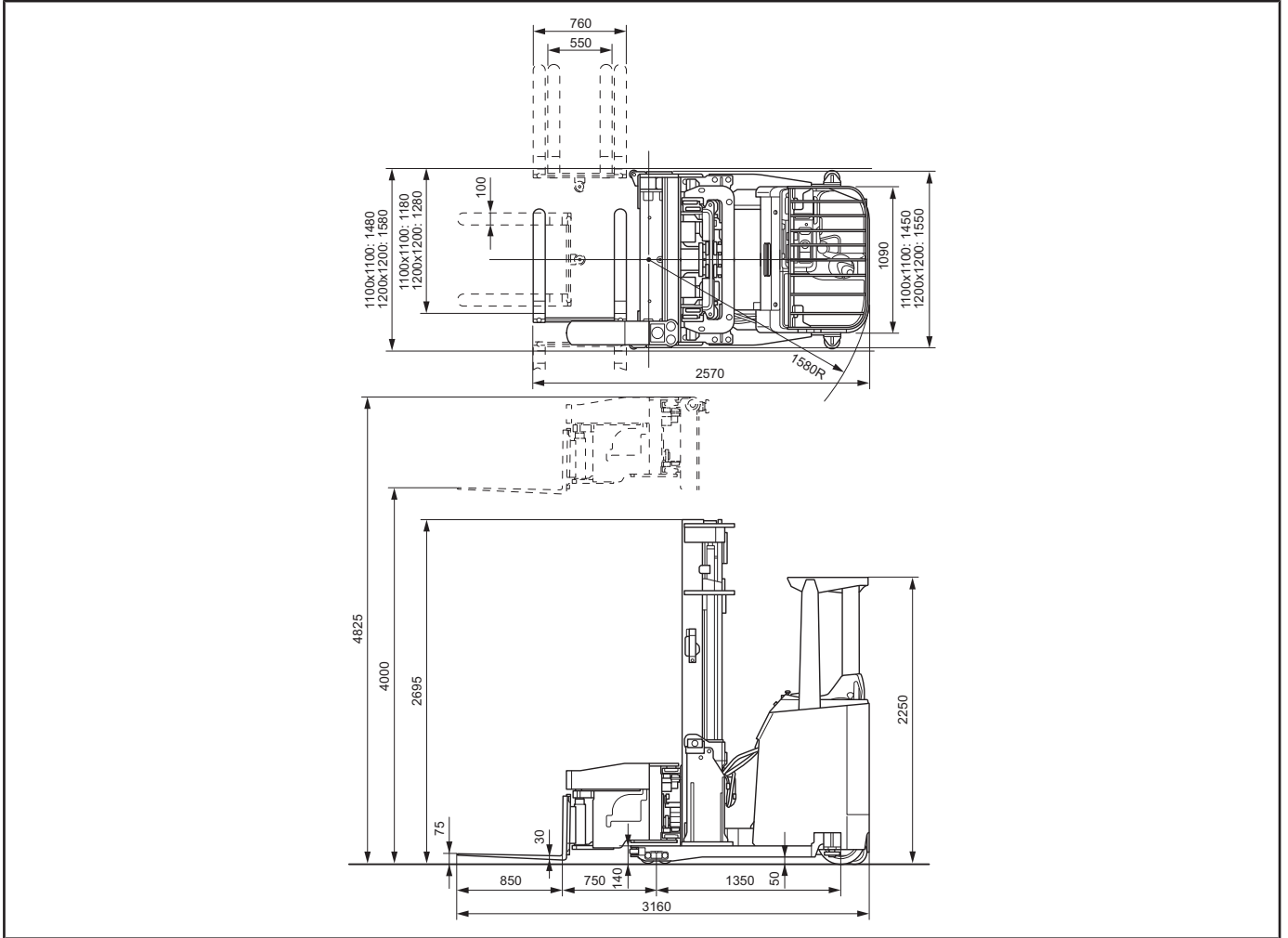

MAST SPECIFICATIONS & RATED CAPACITIES

Mast Type	Maximum Fork Height	Overall Height		Free Lift	Load Capacity	
		Lowered	Extended		550 mm LC	600 mm LC
		mm	mm		kg	kg
Wide Visible Mast (V)	3000	2195	3825	75	700	630
	3500	2445	4325	75	700	630
	4000	2695	4825	75	700	630
	4500	2945	5325	75	630	570
	5000	3195	5825	75	580	500
	5500	3445	6325	75	530	470
	6000	3695	6825	75	500	430

1,000 kg

MAIN VEHICLE SPECIFICATIONS

Manufacturer				TOYOTA	
Model				8RFBA10	
Load Capacity			kg	1000	
Load Center			mm	550	
Operator Position				Stand On	
Tire Type		Front/Rear		Urethane/Rubber	
Wheels (x = driven)		Front/Rear		4/1x+2	
Maximum Fork Height (MFH)			mm	4000	
Free Lift			mm	80	
Fork Size		T x W x L	mm	35x100x850	
Fork Spread (Outside)		MAX./MIN.	mm	760/550	
Overall Length		Fork Facing Forward	mm	3350	
Length to Fork Face		Fork Facing Sideways	mm	2750	
Shift Stroke		Pallet Size 1100 x 1100/1200 x 1200	mm	1180/1280	
Overall Width		Pallet Size 1100 x 1100/1200 x 1200	mm	1450/1550	
Frame Width			mm	1190	
Height of Reach Legs			mm	140	
Mast Lowered Height			mm	2795	
Mast Extended Height			mm	4825	
Overhead Guard Height			mm	2330	
Turning Radius (Outside)			mm	1750	
Load Distance (Centerline of front axle to front face of forks)			mm	770	
Stacking Aisle Width		With pallets 1100x1100	mm	1480	
		With pallets 1200x1200	mm	1580	
Main Aisle Width		With pallets 1100x1100	mm	3100	
		With pallets 1200x1200	mm	3190	
Speed	Travel, Max. (FWD/RVS)	Full Load	km/h	9.5	
		No Load	km/h	10	
	Lifting	Full Load	mm/sec	340	
		No Load	mm/sec	410	
Lowering	Full Load	mm/sec	500		
	No Load	mm/sec	500		
Gradeability *	Full Load/ No Load	3-Minute Ratings	% (tanθ)	10/10	
		5-Minute Ratings	% (tanθ)	10/10	
		30-Minute Ratings	% (tanθ)	10/10	
Total Weight		With MIN. Battery	kg	3840	
Weight Distribution (With MIN. Battery)		Full Load	Front	kg	3430
			Rear	kg	1410
		No Load	Front	kg	2015
			Rear	kg	1825
Tire		Number	Front/Rear	4/1+2	
		Size	Front, Load		127x92
			Rear, Drive		380x164
			Rear, Caster		204x76
Wheelbase			mm	1500	
Tread		Front	mm	1240	
		Rear	mm	690	
Underclearance **		Center of Wheelbase	mm	50	
Brake		Service (Foot)		Disc	
		Parking		Disc	
Battery		Voltage/Capacity (5-hour rating)	MIN.	V/AH	48/280
		Weight (MIN. Capacity Type)		kg	545
Electric Motor		Drive		kW	5.2
		Load Handling		kW	11
		Power Steering		kW	0.35
		Drive			AC inverter
Control Type		Load Handling			AC inverter
		Power Steering			DC chopper
Rotating Speed			sec/180°	12	
Shifting Speed			mm/sec	230	

NOTE: * Computed values.

** The underclearance value is valid under the following conditions: 500 mm load center and the suspension spring in correct adjustment.

DIMENSIONAL DRAWINGS

Unit: mm

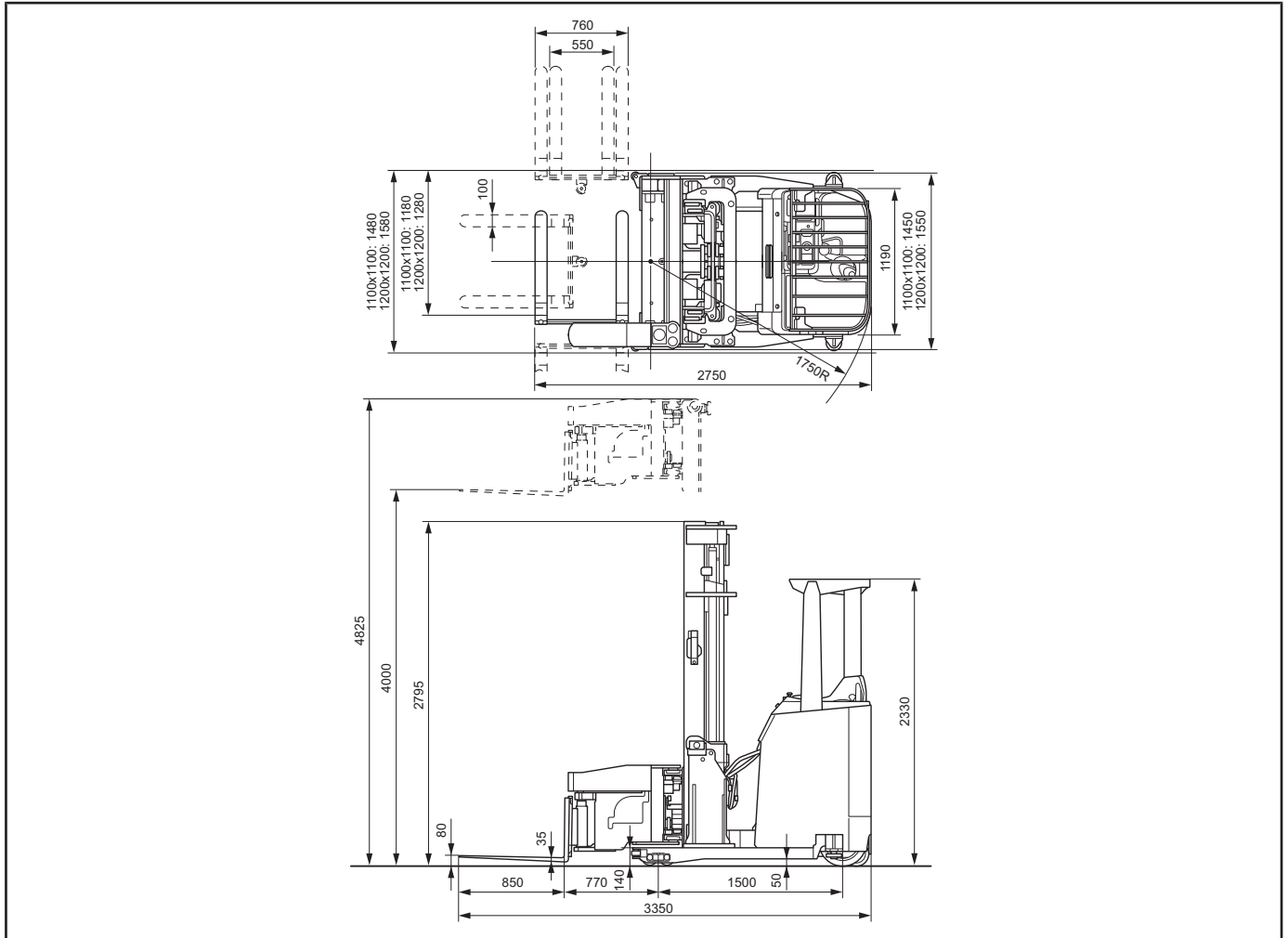

MAST SPECIFICATIONS & RATED CAPACITIES

Mast Type	Maximum Fork Height	Overall Height		Free Lift	Load Capacity	
		Lowered	Extended		550 mm LC	600 mm LC
		mm	mm		kg	kg
Wide Visible Mast (V)	3000	2295	3825	80	1000	900
	3500	2545	4325	80	1000	900
	4000	2795	4825	80	1000	900
	4500	3045	5325	80	1000	900
	5000	3295	5825	80	1000	900
	5500	3545	6325	80	870	770
	6000	3795	6825	80	800	700
Wide Visible Full-Free Lift Three-Stage Mast 2 Cylinders (FSW)	4000	2295	4905	1450	1000	-
	4500	2480	5405	1615	1000	-
	5000	2625	5905	1780	1000	-
	5500	2795	6405	1950	870	-
	6000	2960	6905	2115	800	-
	6500	3125	7405	2280	750	-
	7000	3295	7905	2450	650	-
	7500	3460	8405	2615	550	-

1,000 kg

MAIN VEHICLE SPECIFICATIONS

Manufacturer				TOYOTA
Model				8RFBAS10
Load Capacity			kg	1000
Load Center			mm	550
Operator Position				Stand On
Tire Type		Front/Rear		Urethane/Rubber
Wheels (x = driven)		Front/Rear		4/1x+2
Maximum Fork Height (MFH)			mm	4000
Free Lift			mm	80
Fork Size		T x W x L	mm	35x100x850
Fork Spread (Outside)		MAX./MIN.	mm	760/550
Overall Length		Fork Facing Forward	mm	3500
Length to Fork Face		Fork Facing Sideways	mm	2900
Shift Stroke		Pallet Size 1100 x 1100/1200 x 1200	mm	1180/1280
Overall Width		Pallet Size 1100 x 1100/1200 x 1200	mm	1450/1550
Frame Width			mm	1190
Height of Reach Legs			mm	140
Mast Lowered Height			mm	2795
Mast Extended Height			mm	4825
Overhead Guard Height			mm	2330
Turning Radius (Outside)			mm	1910
Load Distance (Centerline of front axle to front face of forks)			mm	790
Stacking Aisle Width		With pallets 1100x1100	mm	1480
		With pallets 1200x1200	mm	1580
Main Aisle Width		With pallets 1100x1100	mm	3250
		With pallets 1200x1200	mm	3340
Speed	Travel, Max. (FWD/RVS)	Full Load	km/h	9.5
		No Load	km/h	10
	Lifting	Full Load	mm/sec	340
		No Load	mm/sec	410
Lowering	Full Load	mm/sec	500	
	No Load	mm/sec	500	
Gradeability *	Full Load/ No Load	3-Minute Ratings	% (tanθ)	10/10
		5-Minute Ratings	% (tanθ)	10/10
		30-Minute Ratings	% (tanθ)	9/10
Total Weight	With MIN. Battery		kg	4220
	Full Load	Front	kg	3550
Rear		kg	1670	
Weight Distribution (With MIN. Battery)	No Load	Front	kg	2170
		Rear	kg	2050
Tire	Number	Front/Rear		4/1+2
	Size	Front, Load		127x92
		Rear, Drive		380x164
		Rear, Caster		204x76
Wheelbase			mm	1650
Tread	Front		mm	1240
	Rear		mm	690
Underclearance **	Center of Wheelbase		mm	50
Brake	Service (Foot)			Disc
	Parking			Disc
Battery	Voltage/Capacity (5-hour rating)	MIN.	V/AH	48/390
	Weight (MIN. Capacity Type)		kg	680
Electric Motor	Drive		kW	5.2
	Load Handling		kW	11
	Power Steering		kW	0.35
Control Type	Drive			AC inverter
	Load Handling			AC inverter
	Power Steering			DC chopper
Rotating Speed			sec/180°	12
Shifting Speed			mm/sec	230

NOTE: * Computed values.

** The underclearance value is valid under the following conditions: 500 mm load center and the suspension spring in correct adjustment.

DIMENSIONAL DRAWINGS

Unit: mm

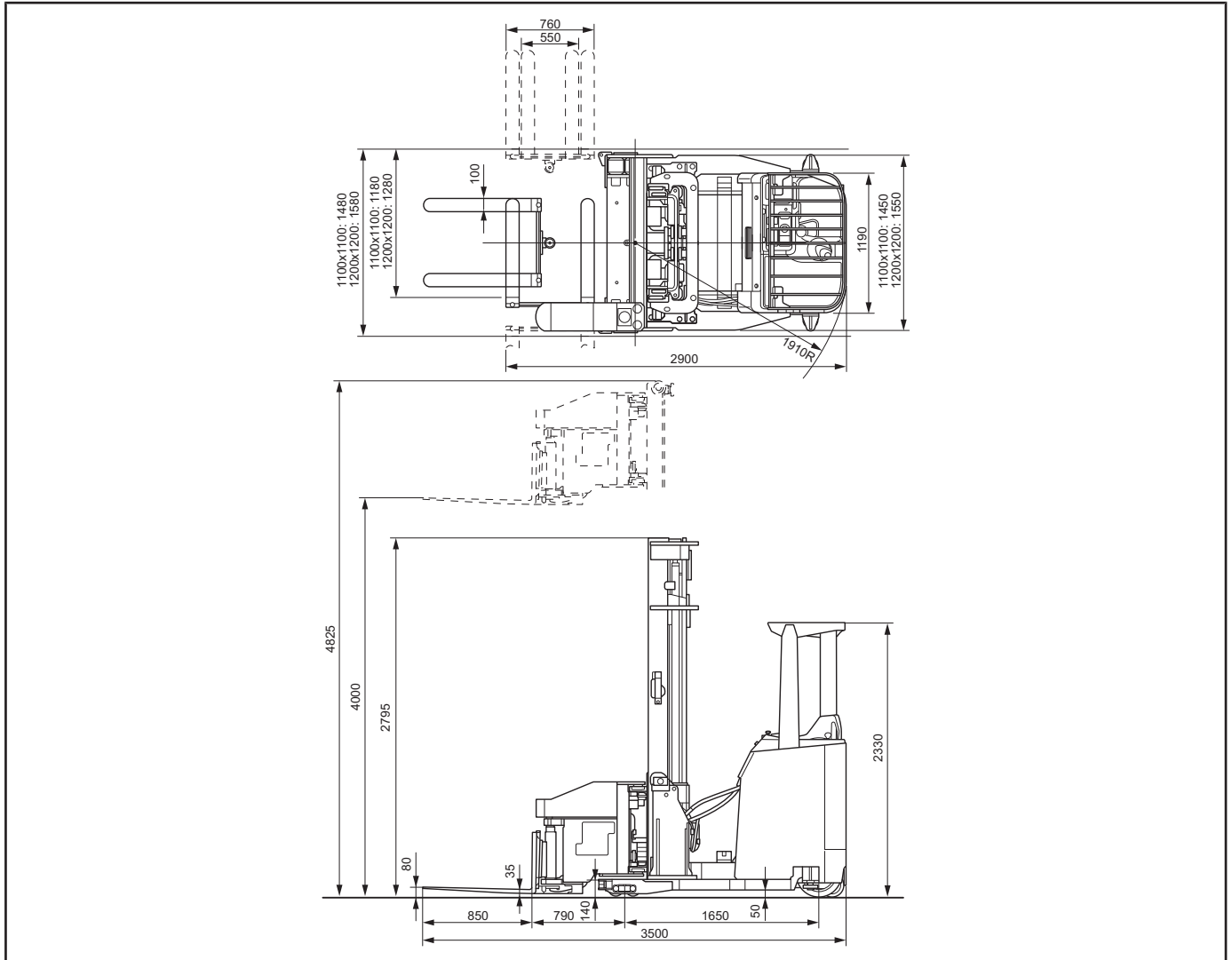

MAST SPECIFICATIONS & RATED CAPACITIES

Mast Type	Maximum Fork Height mm	Overall Height		Free Lift mm	Load Capacity	
		Lowered mm	Extended mm		550 mm LC kg	600 mm LC kg
Wide Visible Mast (V)	3000	2295	3825	80	1000	900
	3500	2545	4325	80	1000	900
	4000	2795	4825	80	1000	900
	4500	3045	5325	80	1000	900
	5000	3295	5825	80	1000	900
	5500	3545	6325	80	1000	900
	6000	3795	6825	80	1000	900
Wide Visible Full-Free Lift Three-Stage Mast 2 Cylinders (FSW)	4000	2295	4905	1450	1000	-
	4500	2460	5405	1615	1000	-
	5000	2625	5905	1780	1000	-
	5500	2795	6405	1950	1000	-
	6000	2960	6905	2115	1000	-
	6500	3125	7405	2280	1000	-
	7000	3295	7905	2450	900	-
7500	3460	8405	2615	800	-	

1,200 kg

MAIN VEHICLE SPECIFICATIONS

Manufacturer				TOYOTA	
Model				8RFBA12	
Load Capacity			kg	1200	
Load Center			mm	550	
Operator Position				Stand On	
Tire Type		Front/Rear		Urethane/Rubber	
Wheels (x = driven)		Front/Rear		4/1x+2	
Maximum Fork Height (MFH)			mm	4000	
Free Lift			mm	80	
Fork Size		T x W x L	mm	40x120x920	
Fork Spread (Outside)		MAX./MIN.	mm	760/550	
Overall Length		Fork Facing Forward	mm	3390	
Length to Fork Face		Fork Facing Sideways	mm	2750	
Shift Stroke		Pallet Size 1100 x 1100/1200 x 1200	mm	1265/1365	
Overall Width		Pallet Size 1100 x 1100/1200 x 1200	mm	1550/1650	
Frame Width			mm	1190	
Height of Reach Legs			mm	140	
Mast Lowered Height			mm	2795	
Mast Extended Height			mm	4825	
Overhead Guard Height			mm	2330	
Turning Radius (Outside)			mm	1750	
Load Distance (Centerline of front axle to front face of forks)			mm	775	
Stacking Aisle Width		With pallets 1100x1100	mm	1580	
		With pallets 1200x1200	mm	1680	
Main Aisle Width		With pallets 1100x1100	mm	3080	
		With pallets 1200x1200	mm	3170	
Speed	Travel, Max. (FWD/RVS)	Full Load	km/h	9	
		No Load	km/h	9.5	
	Lifting	Full Load	mm/sec	325	
		No Load	mm/sec	410	
	Lowering	Full Load	mm/sec	500	
		No Load	mm/sec	500	
Gradeability *	Full Load/ No Load	3-Minute Ratings	% (tanθ)	10/10	
		5-Minute Ratings	% (tanθ)	10/10	
		30-Minute Ratings	% (tanθ)	9/10	
Total Weight		With MIN. Battery	kg	4190	
Weight Distribution (With MIN. Battery)		Full Load	Front	kg	4010
			Rear	kg	1380
		No Load	Front	kg	2310
			Rear	kg	1880
Tire		Number	Front/Rear	4/1+2	
		Size	Front, Load		140x127
			Rear, Drive		380x164
			Rear, Caster		204x76
Wheelbase			mm	1500	
Tread		Front	mm	1305	
		Rear	mm	690	
Underclearance **		Center of Wheelbase	mm	50	
Brake		Service (Foot)		Disc	
		Parking		Disc	
Battery		Voltage/Capacity (5-hour rating)	MIN.	V/AH	48/280
		Weight (MIN. Capacity Type)		kg	545
Electric Motor		Drive	kW	5.2	
		Load Handling	kW	11	
		Power Steering	kW	0.35	
Control Type		Drive		AC inverter	
		Load Handling		AC inverter	
		Power Steering		DC chopper	
Rotating Speed			sec/180°	12	
Shifting Speed			mm/sec	230	

NOTE: * Computed values.

** The underclearance value is valid under the following conditions: 500 mm load center and the suspension spring in correct adjustment.

DIMENSIONAL DRAWINGS

Unit: mm

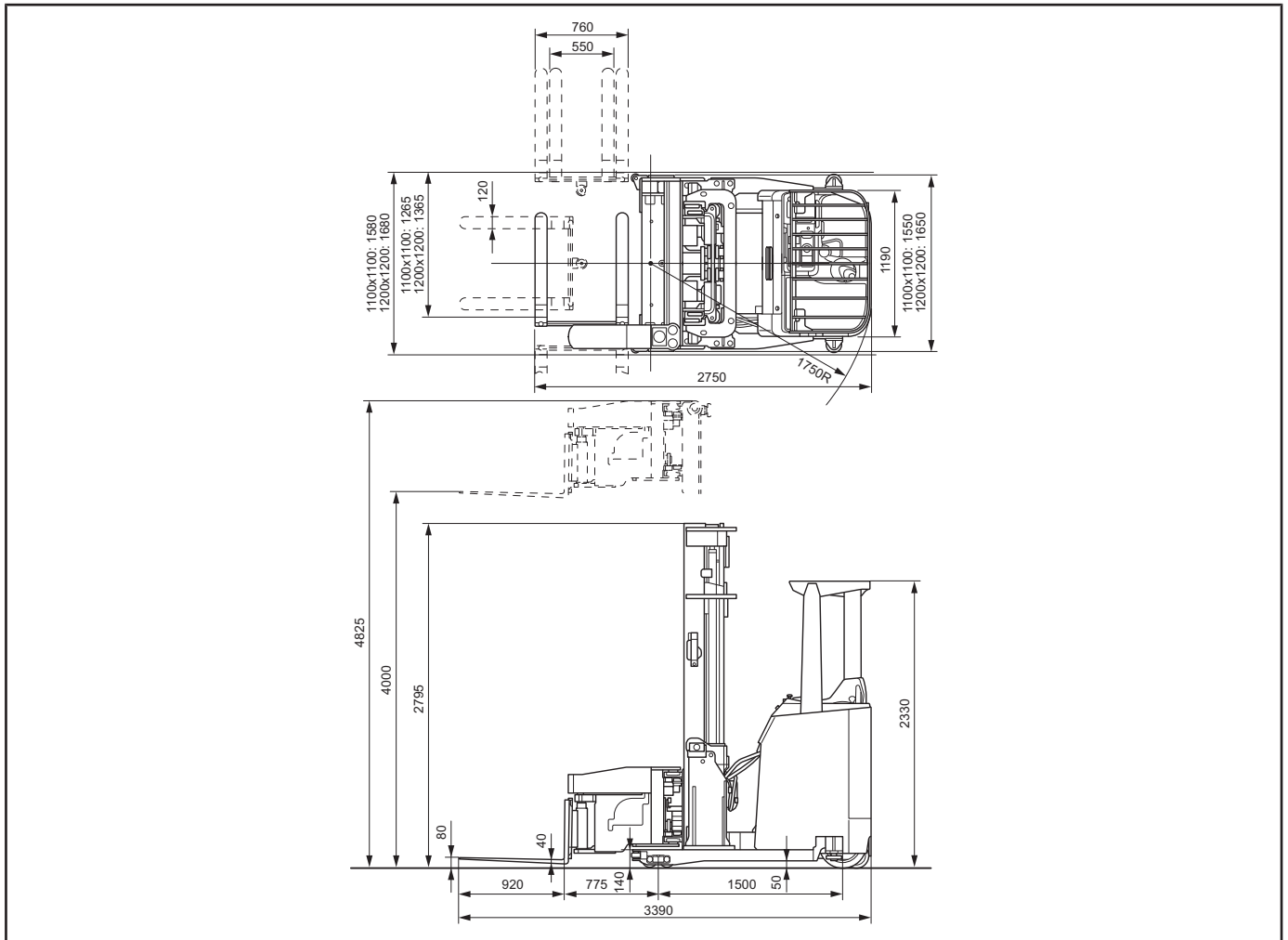

MAST SPECIFICATIONS & RATED CAPACITIES

Mast Type	Maximum Fork Height	Overall Height		Free Lift	Load Capacity	
		Lowered	Extended		550 mm LC	600 mm LC
		mm	mm		kg	kg
Wide Visible Mast (V)	3000	2295	3825	80	1200	1200
	3500	2545	4325	80	1200	1200
	4000	2795	4825	80	1200	1200
	4500	3045	5325	80	1170	1170
	5000	3295	5825	80	1100	1100
	5500	3545	6325	80	1000	1000
	6000	3795	6825	80	1000	1000
Wide Visible Full-Free Lift Three-Stage Mast 2 Cylinders (FSW)	4000	2295	4905	1450	1200	-
	4500	2480	5405	1615	1170	-
	5000	2625	5905	1780	1070	-
	5500	2795	6405	1950	1000	-
	6000	2960	6905	2115	950	-
	6500	3125	7405	2280	900	-
	7000	3295	7905	2450	850	-
	7500	3460	8405	2615	800	-

1,200 kg

MAIN VEHICLE SPECIFICATIONS

Manufacturer				TOYOTA	
Model				8RFBAS12	
Load Capacity			kg	1200	
Load Center			mm	550	
Operator Position				Stand On	
Tire Type		Front/Rear		Urethane/Rubber	
Wheels (x = driven)		Front/Rear		4/1x+2	
Maximum Fork Height (MFH)			mm	4000	
Free Lift			mm	80	
Fork Size		T x W x L	mm	40x120x920	
Fork Spread (Outside)		MAX./MIN.	mm	760/550	
Overall Length		Fork Facing Forward	mm	3580	
Length to Fork Face		Fork Facing Sideways	mm	2900	
Shift Stroke		Pallet Size 1100 x 1100/1200 x 1200	mm	1265/1365	
Overall Width		Pallet Size 1100 x 1100/1200 x 1200	mm	1550/1650	
Frame Width			mm	1190	
Height of Reach Legs			mm	140	
Mast Lowered Height			mm	2795	
Mast Extended Height			mm	4825	
Overhead Guard Height			mm	2330	
Turning Radius (Outside)			mm	1910	
Load Distance (Centerline of front axle to front face of forks)			mm	795	
Stacking Aisle Width		With pallets 1100x1100	mm	1580	
		With pallets 1200x1200	mm	1680	
Main Aisle Width		With pallets 1100x1100	mm	3230	
		With pallets 1200x1200	mm	3330	
Speed	Travel, Max. (FWD/RVS)	Full Load	km/h	9	
		No Load	km/h	9.5	
	Lifting	Full Load	mm/sec	325	
		No Load	mm/sec	410	
	Lowering	Full Load	mm/sec	500	
		No Load	mm/sec	500	
Gradeability *	Full Load/ No Load	3-Minute Ratings	% (tanθ)	10/10	
		5-Minute Ratings	% (tanθ)	10/10	
		30-Minute Ratings	% (tanθ)	9/10	
Total Weight		With MIN. Battery	kg	4250	
Weight Distribution (With MIN. Battery)		Full Load	Front	kg	3870
			Rear	kg	1580
		No Load	Front	kg	2210
			Rear	kg	2040
Tire		Number	Front/Rear	4/1+2	
		Size	Front, Load		140x127
			Rear, Drive		380x164
			Rear, Caster		204x76
Wheelbase			mm	1650	
Tread		Front	mm	1305	
		Rear	mm	690	
Underclearance **		Center of Wheelbase	mm	50	
Brake		Service (Foot)		Disc	
		Parking		Disc	
Battery		Voltage/Capacity (5-hour rating)	MIN.	V/AH	48/390
		Weight (MIN. Capacity Type)	kg		680
Electric Motor		Drive	kW	5.2	
		Load Handling	kW	11	
		Power Steering	kW	0.35	
		Drive		AC inverter	
Control Type		Load Handling		AC inverter	
		Power Steering		DC chopper	
Rotating Speed			sec/180°	12	
Shifting Speed			mm/sec	230	

NOTE: * Computed values.

** The underclearance value is valid under the following conditions: 500 mm load center and the suspension spring in correct adjustment.

DIMENSIONAL DRAWINGS

Unit: mm

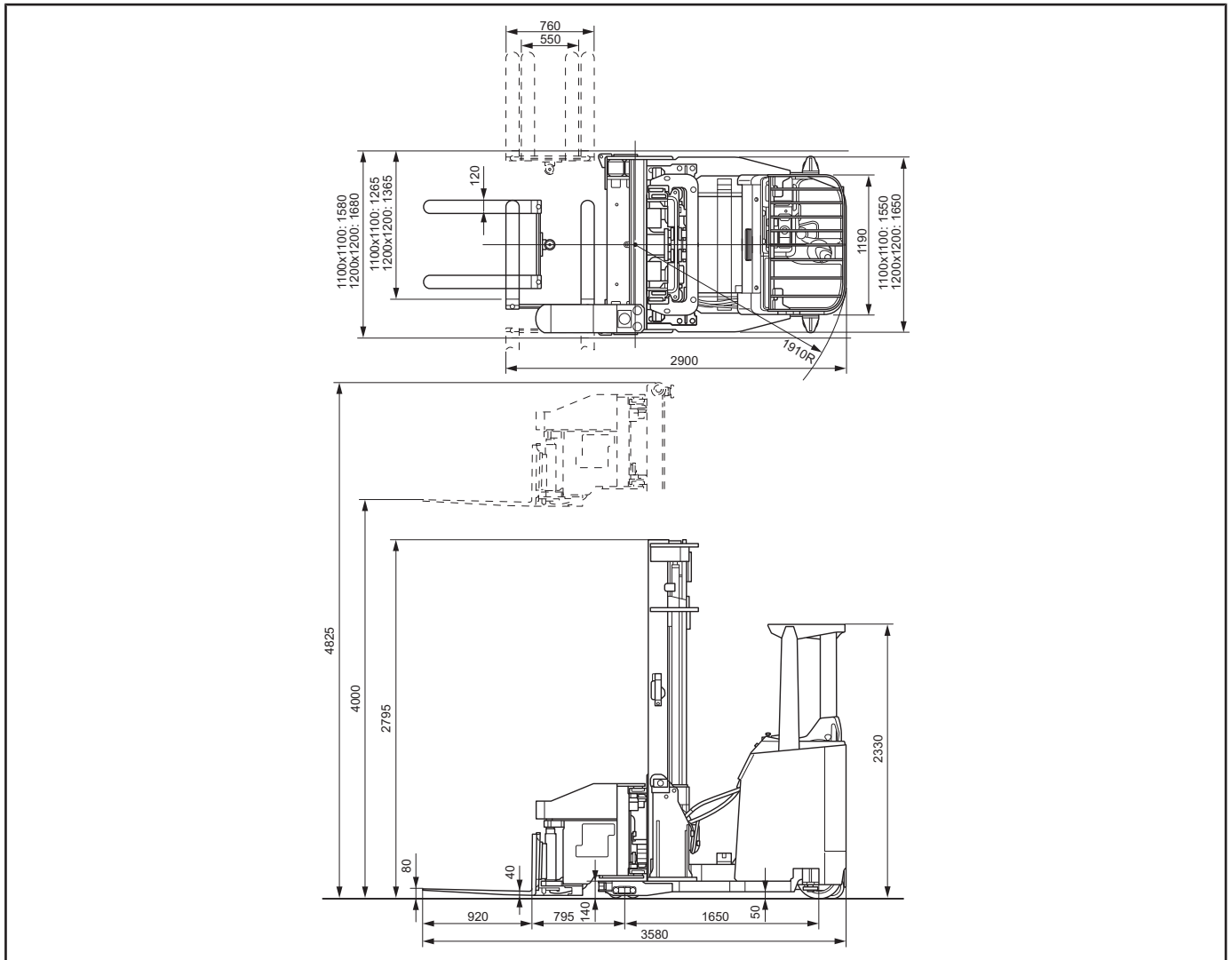

MAST SPECIFICATIONS & RATED CAPACITIES

Mast Type	Maximum Fork Height	Overall Height		Free Lift	Load Capacity	
		Lowered	Extended		550 mm LC	600 mm LC
	mm	mm	mm	mm	kg	kg
Wide Visible Mast (V)	3000	2295	3825	80	1200	1100
	3500	2545	4325	80	1200	1100
	4000	2795	4825	80	1200	1100
	4500	3045	5325	80	1200	1100
	5000	3295	5825	80	1200	1100
	5500	3545	6325	80	1150	1050
	6000	3795	6825	80	1100	1000
Wide Visible Full-Free Lift Three-Stage Mast 2 Cylinders (FSW)	4000	2295	4905	1450	1200	-
	4500	2460	5405	1615	1200	-
	5000	2625	5905	1780	1200	-
	5500	2795	6405	1950	1150	-
	6000	2960	6905	2115	1100	-
	6500	3125	7405	2280	1050	-
	7000	3295	7905	2450	1020	-
7500	3460	8405	2615	1000	-	

1,500 kg

MAIN VEHICLE SPECIFICATIONS

Manufacturer				TOYOTA
Model				8RFBA15
Load Capacity			kg	1450
Load Center			mm	550
Operator Position				Stand On
Tire Type		Front/Rear		Urethane/Rubber
Wheels (x = driven)		Front/Rear		4/1x+2
Maximum Fork Height (MFH)			mm	4000
Free Lift			mm	80
Fork Size		T x W x L	mm	40x120x920
Fork Spread (Outside)		MAX./MIN.	mm	760/550
Overall Length		Fork Facing Forward	mm	3590
Length to Fork Face		Fork Facing Sideways	mm	2900
Shift Stroke		Pallet Size 1100 x 1100/1200 x 1200	mm	1235/1335
Overall Width		Pallet Size 1100 x 1100/1200 x 1200	mm	1550/1650
Frame Width			mm	1190
Height of Reach Legs			mm	140
Mast Lowered Height			mm	3045
Mast Extended Height			mm	5075
Overhead Guard Height			mm	2330
Turning Radius (Outside)			mm	1910
Load Distance (Centerline of front axle to front face of forks)			mm	790
Stacking Aisle Width		With pallets 1100x1100	mm	1580
		With pallets 1200x1200	mm	1680
Main Aisle Width		With pallets 1100x1100	mm	3260
		With pallets 1200x1200	mm	3350
Speed	Travel, Max. (FWD/RVS)	Full Load	km/h	8.5
		No Load	km/h	9
	Lifting	Full Load	mm/sec	295
		No Load	mm/sec	400
Lowering	Full Load	mm/sec	500	
	No Load	mm/sec	500	
Gradeability *	Full Load/ No Load	3-Minute Ratings	% (tanθ)	10/10
		5-Minute Ratings	% (tanθ)	10/10
		30-Minute Ratings	% (tanθ)	8/10
Total Weight	With MIN. Battery		kg	4710
Weight Distribution (With MIN. Battery)	Full Load	Front	kg	4610
		Rear	kg	1550
	No Load	Front	kg	2610
		Rear	kg	2100
Tire	Number	Front/Rear		4/1+2
	Size	Front, Load		140x127
		Rear, Drive		380x164
		Rear, Caster		204x76
Wheelbase			mm	1650
Tread	Front		mm	1305
	Rear		mm	690
Underclearance **	Center of Wheelbase		mm	50
Brake	Service (Foot)			Disc
	Parking			Disc
Battery	Voltage/Capacity (5-hour rating)	MIN.	V/AH	48/320
	Weight (MIN. Capacity Type)		kg	595
Electric Motor	Drive		kW	5.2
	Load Handling		kW	11
	Power Steering		kW	0.35
	Drive			AC inverter
Control Type	Load Handling			AC inverter
	Power Steering			DC chopper
Rotating Speed			sec/180°	12
Shifting Speed			mm/sec	230

NOTE: * Computed values.

** The underclearance value is valid under the following conditions: 500 mm load center and the suspension spring in correct adjustment.

DIMENSIONAL DRAWINGS

Unit: mm

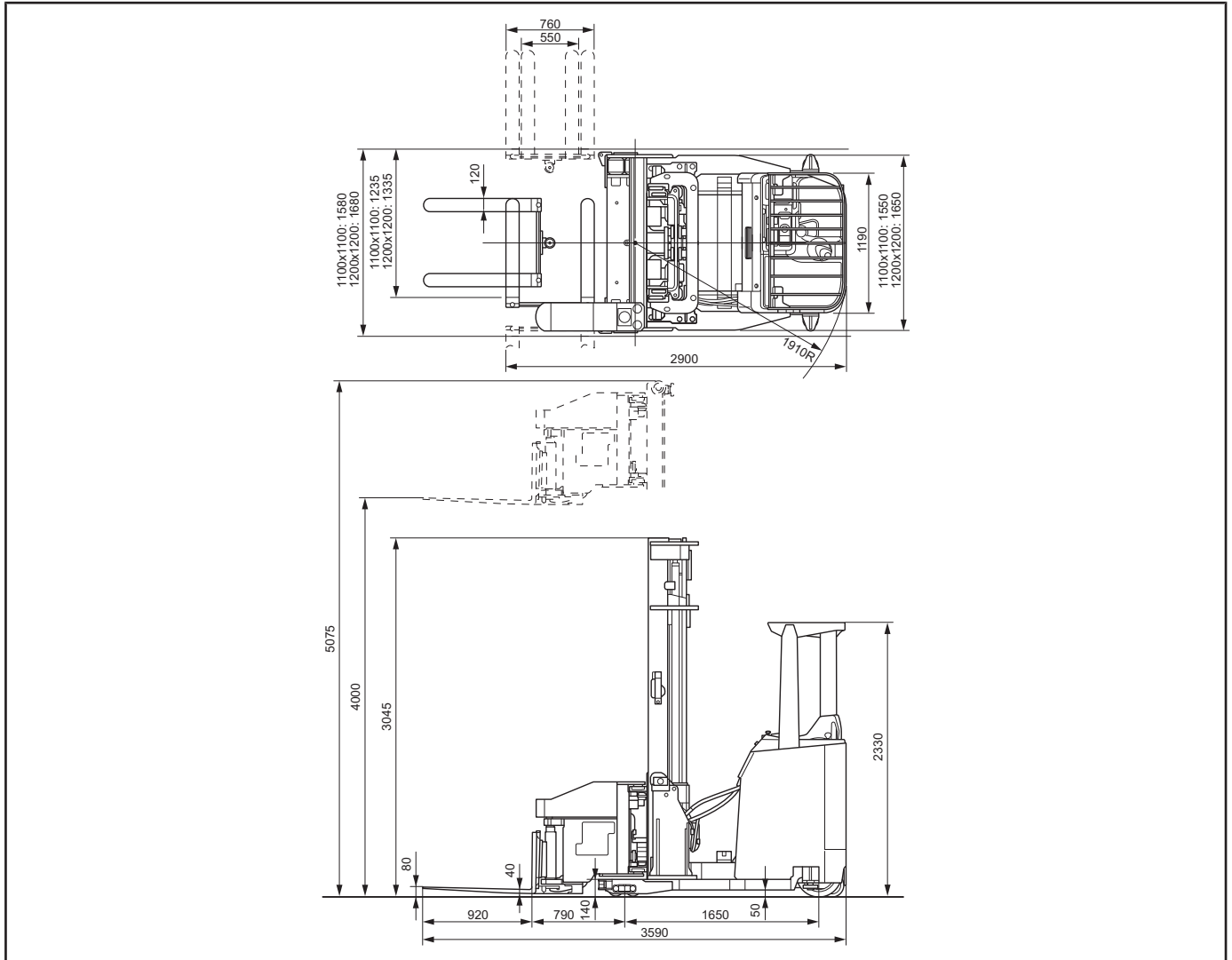

MAST SPECIFICATIONS & RATED CAPACITIES

Mast Type	Maximum Fork Height	Overall Height		Free Lift	Load Capacity	
		Lowered	Extended		550 mm LC	600 mm LC
		mm	mm		kg	kg
Wide Visible Mast (V)	3000	2545	4075	80	1500	1370
	3500	2795	4575	80	1500	1320
	4000	3045	5075	80	1450	1270
	4500	3295	5575	80	1330	1150
	5000	3545	6075	80	1230	1070
	5500	3795	6575	80	1070	950
	6000	4045	7075	80	970	870
Wide Visible Full-Free Lift Three-Stage Mast 2 Cylinders (FSW)	4000	2460	5075	1445	1450	-
	4500	2625	5575	1610	1330	-
	5000	2795	6075	1780	1230	-
	5500	2960	6575	1945	1070	-
	6000	3125	7075	2110	970	-
	6500	3295	7575	2280	900	-

1,500 kg

MAIN VEHICLE SPECIFICATIONS

Manufacturer				TOYOTA
Model				8RFBAS15
Load Capacity			kg	1500
Load Center			mm	550
Operator Position				Stand On
Tire Type		Front/Rear		Urethane/Rubber
Wheels (x = driven)		Front/Rear		4/1x+2
Maximum Fork Height (MFH)			mm	4000
Free Lift			mm	80
Fork Size		T x W x L	mm	40x120x920
Fork Spread (Outside)		MAX./MIN.	mm	760/550
Overall Length		Fork Facing Forward	mm	3590
Length to Fork Face		Fork Facing Sideways	mm	2900
Shift Stroke		Pallet Size 1100 x 1100/1200 x 1200	mm	1235/1335
Overall Width		Pallet Size 1100 x 1100/1200 x 1200	mm	1550/1650
Frame Width			mm	1190
Height of Reach Legs			mm	140
Mast Lowered Height			mm	3045
Mast Extended Height			mm	5075
Overhead Guard Height			mm	2330
Turning Radius (Outside)			mm	1910
Load Distance (Centerline of front axle to front face of forks)			mm	790
Stacking Aisle Width		With pallets 1100x1100	mm	1580
		With pallets 1200x1200	mm	1680
Main Aisle Width		With pallets 1100x1100	mm	3240
		With pallets 1200x1200	mm	3340
Speed	Travel, Max. (FWD/RVS)	Full Load	km/h	8.5
		No Load	km/h	9
	Lifting	Full Load	mm/sec	295
		No Load	mm/sec	400
Lowering	Full Load	mm/sec	500	
	No Load	mm/sec	500	
Gradeability *	Full Load/ No Load	3-Minute Ratings	% (tanθ)	10/10
		5-Minute Ratings	% (tanθ)	10/10
		30-Minute Ratings	% (tanθ)	8/10
Total Weight	With MIN. Battery		kg	4910
	Weight Distribution (With MIN. Battery)	Full Load	Front	kg
Rear			kg	1650
No Load		Front	kg	2690
		Rear	kg	2220
Tire	Number	Front/Rear		4/1+2
		Size	Front, Load	140x127
	Size	Rear, Drive		380x164
		Rear, Caster		204x76
Wheelbase			mm	1650
Tread	Front		mm	1305
	Rear		mm	690
Underclearance **	Center of Wheelbase		mm	50
Brake	Service (Foot)			Disc
	Parking			Disc
Battery	Voltage/Capacity (5-hour rating)	MIN.	V/AH	48/390
	Weight (MIN. Capacity Type)		kg	680
Electric Motor	Drive		kW	5.2
	Load Handling		kW	11
	Power Steering		kW	0.35
Control Type	Drive			AC inverter
	Load Handling			AC inverter
	Power Steering			DC chopper
Rotating Speed			sec/180°	12
Shifting Speed			mm/sec	230

NOTE: * Computed values.

** The underclearance value is valid under the following conditions: 500 mm load center and the suspension spring in correct adjustment.

DIMENSIONAL DRAWINGS

Unit: mm

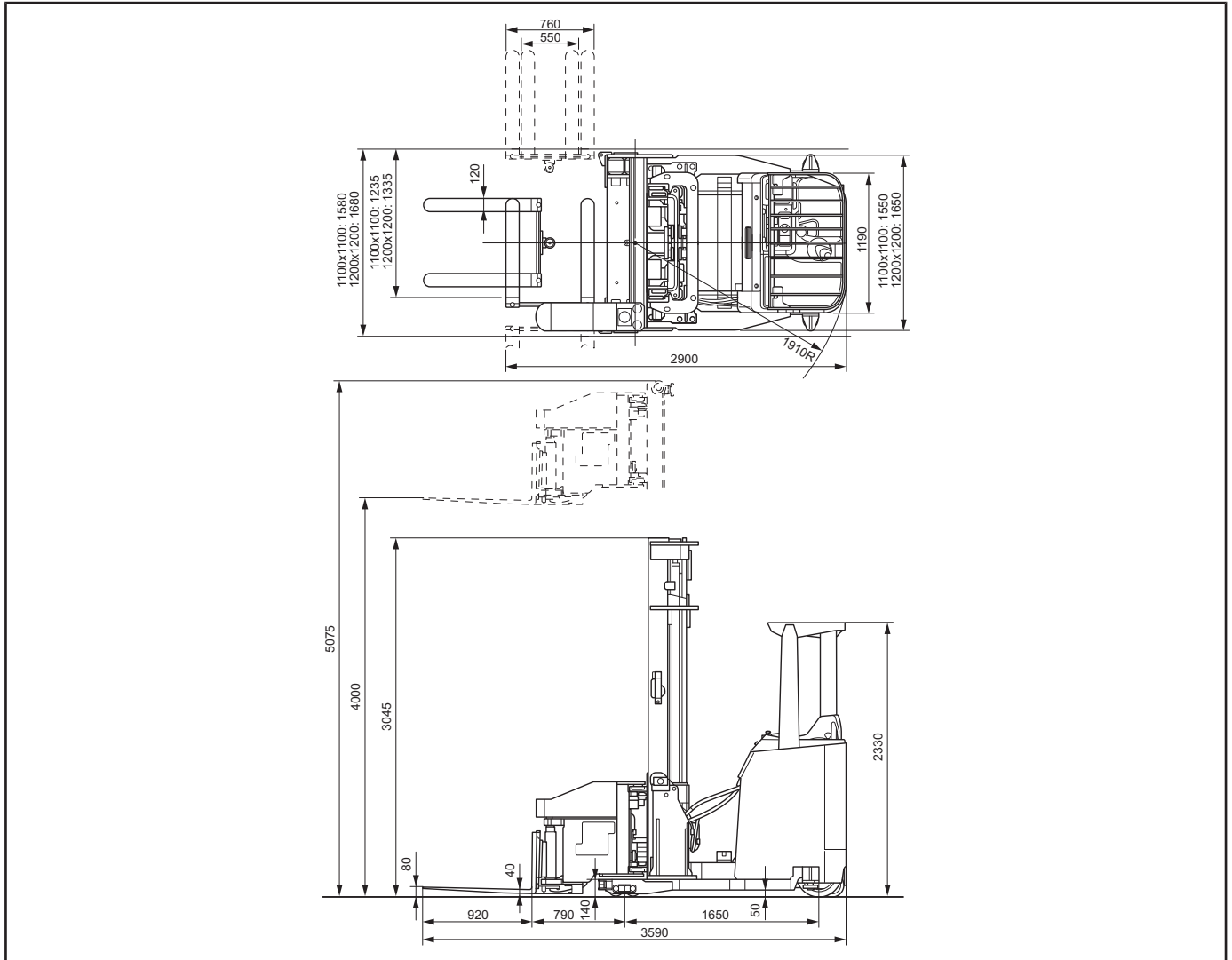

MAST SPECIFICATIONS & RATED CAPACITIES

Mast Type	Maximum Fork Height	Overall Height		Free Lift	Load Capacity	
		Lowered	Extended		550 mm LC	600 mm LC
		mm	mm		kg	kg
Wide Visible Mast (V)	3000	2545	4075	80	1500	1370
	3500	2795	4575	80	1500	1370
	4000	3045	5075	80	1500	1370
	4500	3295	5575	80	1500	1370
	5000	3545	6075	80	1350	1250
	5500	3795	6575	80	1230	1130
	6000	4045	7075	80	1150	1050
Wide Visible Full-Free Lift Three-Stage Mast 2 Cylinders (FSW)	4000	2460	5075	1445	1500	-
	4500	2625	5575	1610	1500	-
	5000	2795	6075	1780	1350	-
	5500	2960	6575	1945	1230	-
	6000	3125	7075	2110	1150	-
	6500	3295	7575	2280	1080	-
	7000	3460	8075	2445	1030	-
7500	3625	8575	2610	1000	-	

STANDARD EQUIPMENT

8RFBA7.10.12.15, 8RFBAS10.12.15

- Wide Visible Mast (V) [MFH: 4000 mm]
- Electric swiveling fork
- Joystick lever
- Operator Presence Sensing System (OPS)
- Shockless landing
- Load-handling regenerative system
- Brake regenerative system
- Deluxe multifunction display (Maximum speed control, Over speed alarm, Digital diagnosis, Battery capacity indicator, Speedometer, Power meter, Wheel indicator, Direction indicator, Load weight indicator, Scheduled maintenance hour meter, Battery overdischarge warning, Battery remaining-charge warning, Overheat warning, Low temperature warning, Return-to-neutral warning, Manager's secondary password setting)
- Anti-rollback
- Suspension control
- Automatic vehicle-speed control
- Automatic turn-speed control
- Power select function
- Power keep function
- Auto power-off function
- Headlights
- Turn signal lights
- Electric horn
- Overhead guard with rear-positioned headguard pillar
- Emergency unplug lever
- Electric power steering (EPS)
- Back support with integrated assist grip
- Assist grip for left hand
- Arm pad
- Spacious flat top panel
- Pencil holder
- Cup holder

Availability and specifications are determined by market and are subject to change without notice.
Please consult your Toyota representative for details.

All rights reserved by Toyota Industries Corporation.